

Miniature Interface Coaxial Switch, DC to 10 GHz

MS-162 Series

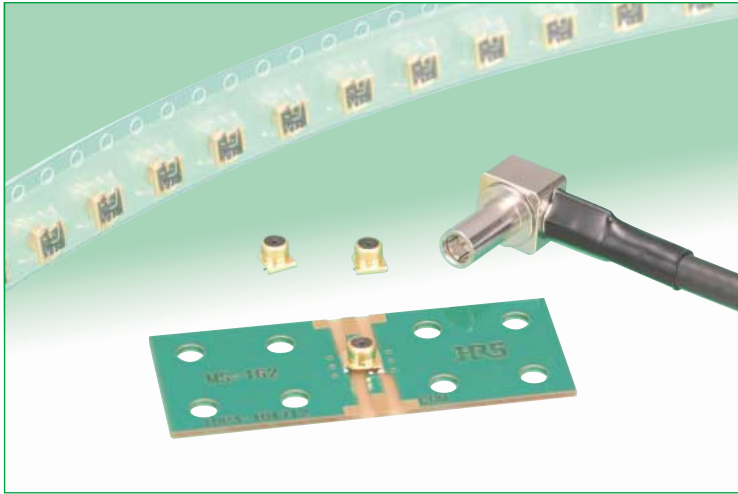

Overview

Designed to be used as the interface antenna connection for portable terminal devices as well as circuit testing on microwave boards (DC to 10GHz) the coaxial switch offers high performance, low loss, extremely high durability and reliability, in a small and lightweight package.

Normally closed, the circuit is re-directed to the plug side by the mating of the plug with the receptacle.

Features

1. Low insertion loss

0.08 dB typical at 1 GHz
 0.12 dB typical at 2 GHz
 (not mated with the plug)

2. Space-saving design

3.5 mm x 3.1 mm occupied board space.

3. Low profile

2.5 mm max. protrusion above the board.

4. Lightweight

0.044 g total weight

5. Durability

12, 000 mating/unmating cycles, with corresponding plug.

6. Critical area protection

MS-162 (Receptacle) contact has nickel plating areas to prevent solder wicking into critical areas.

7. Board placement with automatic equipment.

Packaged on tape-and-reel.

8. Self alignment

When mating, plug and receptacle will self align in horizontal axis within 0.5mm.

9. RoHS compliant

All components and materials comply with the requirements of the EU Directive 2002/95/EC.

Applications

- *Wireless communication modules (Bluetooth, WLAN, UWB, ZigBee)
- *Portable terminals, notebook computers, ETC, POS terminals, GPS terminals, PDA, and any small devices requiring verification of antenna/circuit performance and re-direction of the transmission.

Comparison with the existing MS-147

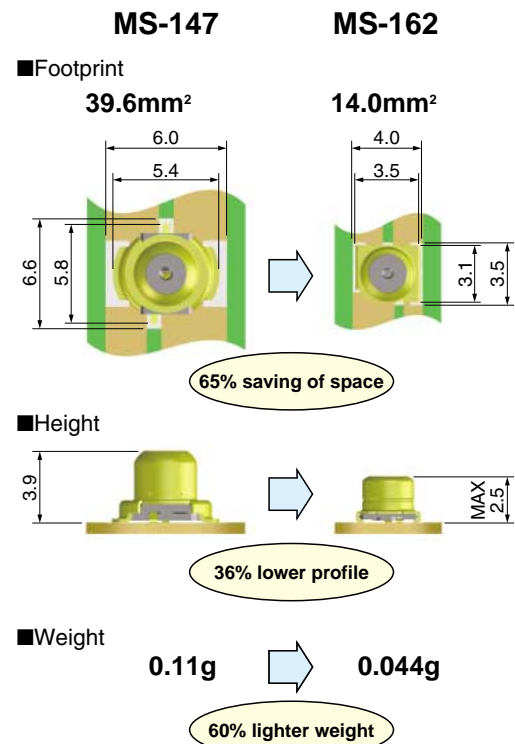

Plugs

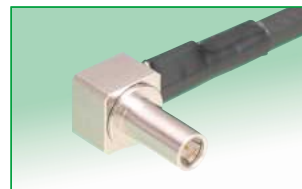

MS-162-C(LP)-1

SMA conversion adapter

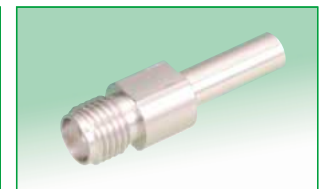

MS-162-HRMJ-1

■ Product Specifications

	Not mated with the plug	Open (Mated with MS-162-HRMJ-1)
Operating temperature range	-40°C to +85°C	
Rated power	4W	
Frequency range	DC to 10GHz	
V.S.W.R.	1.2 max. (DC to 3GHz) 1.5 max. (3GHz to 6GHz) 1.7 max. (6GHz to 10GHz)	1.2 max. (DC to 3GHz) 1.6 max. (3GHz to 6GHz) 1.7 max. (6GHz to 10GHz)
Insertion loss	0.15 dBmax. (DC to 2GHz) 0.2 dBmax. (2GHz to 3GHz) 0.4 dBmax. (3GHz to 6GHz) 0.7 dBmax. (6GHz to 10GHz)	0.2 dBmax. (DC to 2GHz) 0.3 dBmax. (2GHz to 3GHz) 0.5 dBmax. (3GHz to 6GHz) 0.7 dBmax. (6GHz to 10GHz)
Isolation loss	—————	25 dBmin. (DC to 1GHz) 20 dBmin. (1GHz to 3GHz) 14 dBmin. (3GHz to 6GHz) 12 dBmin. (6GHz to 10GHz)

Item	Specification	Conditions
1. Contact resistance	100 mΩ max.	100 mA
2. Insulation resistance	1000 MΩ min.	100 V DC
3. Withstanding voltage	No flashover or insulation breakdown	100 V AC / 1 minute
4. Vibration	No electrical discontinuity of 10 μs or more	Frequency: 10 to 55 Hz, single amplitude of 1.5 mm, 2 hours in each of the 3 axis.
5. Shock	No electrical discontinuity of 10 μs or more	Acceleration of 490 m/s ² , 6 ms duration, sine half-wave waveform, 3 cycles in each of the 3 axis.
6. Humidity	Contact resistance: 100 mΩ max. Insulation resistance: 10 MΩ min.	96 hours at 40°C, RH of 90% to 95%
7. Thermal shock	Contact resistance: 100 mΩ max. Insulation resistance: 10 MΩ min.	Temperature: -55°C → +5°C to +35°C → +85°C → +5°C to +35°C Time: 30 → 5 max. → 30 → 5max. (Minutes) 100 cycles
8. Durability (mating/un-mating, with corresponding plug)	Contact resistance: 100 mΩ max.	12, 000 cycles

■ Materials

Part	Material	Finish	Remarks
Shell	Brass	Gold plated	—————
Insulators	Polyamide	—————	UL94V-0
Common terminal	Beryllium copper	Partially gold plated (Nickel barrier)	—————
Antenna terminal	Phosphor bronze	Partially gold plated (Nickel barrier)	—————

◆ High Frequency Characteristics (Typical)

● NORMALLY CLOSED(N.C) ~ (Not mated with the plug)



● OPEN(N.O) ~ (Mated with the plug)

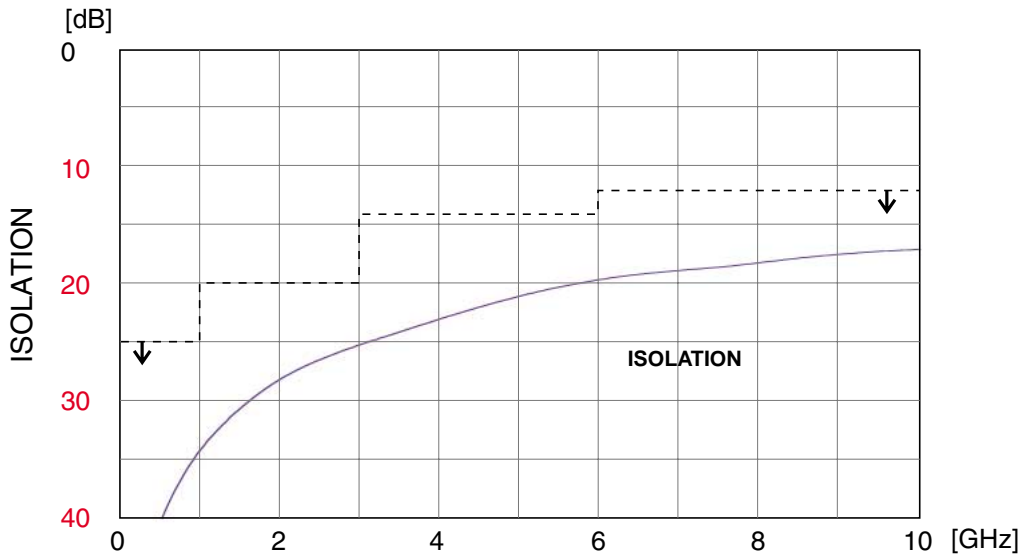
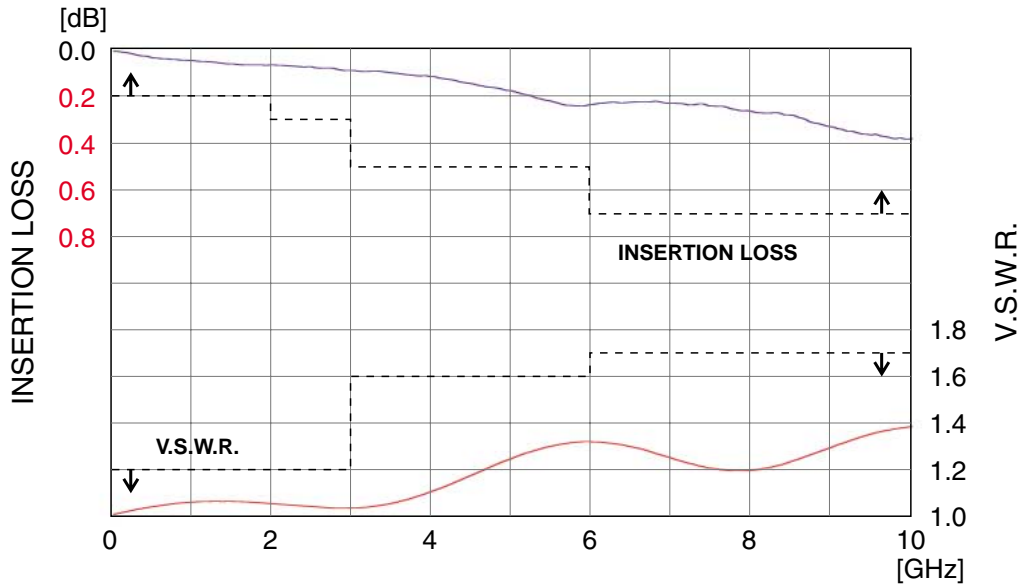

■ Receptacle

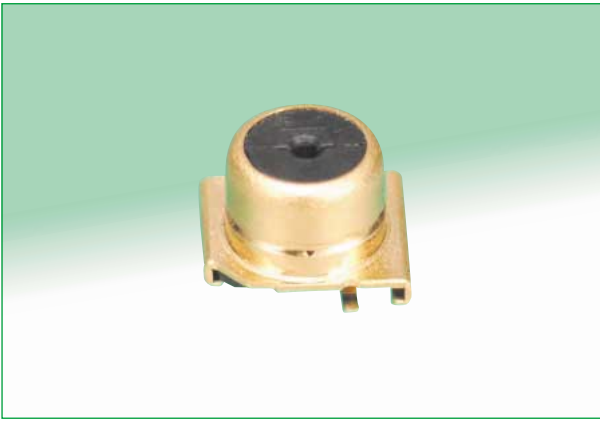

Part Number	CL No.	Packaging	RoHS
MS-162	358-0208-3	3, 000 pieces/reel	YES
MS-162 (01)	358-0208-3-01	100 pieces/bag	

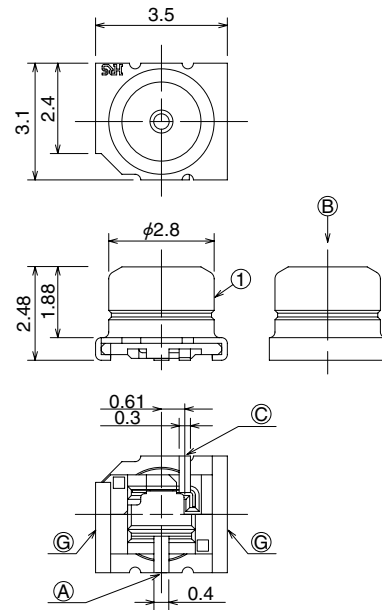

◆ Circuit diagram

Not mated with the plug (N.C)

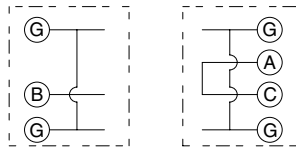

MS-162 Plug

MS-162

Mated with the plug (N.O)

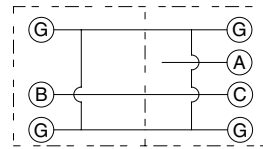



MS-162 Plug

MS-162

◆ PCB mounting pattern and metal mask dimensions

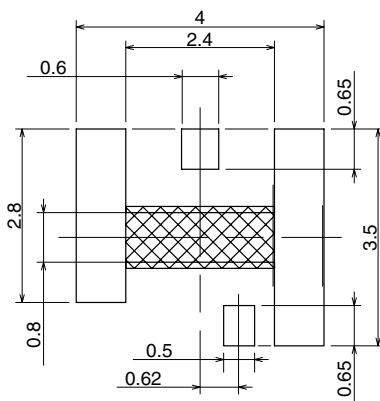
PCB mounting pattern



 area show the conductive pattern prohibited area.

Metal mask dimensions

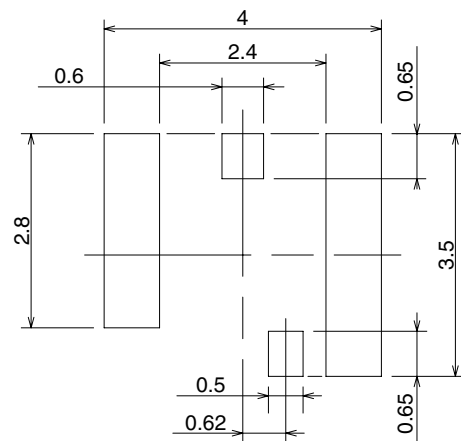

■ Plug

Part Number	CL No.	RoHS
MS-162-C(LP)-1	358-0222-4	YES

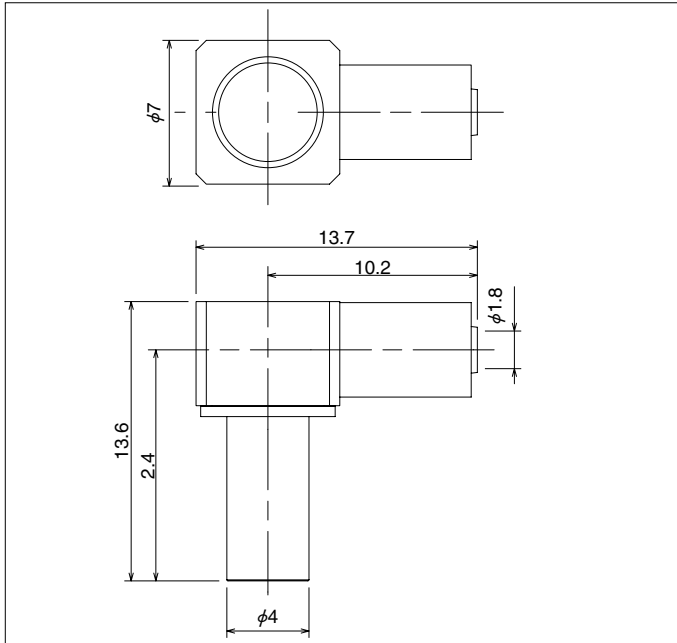

Applicable cable: 1.5D-HQEW, 1.5D-QEW (Fujikura Ltd.)

◆ Recommended Temperature profile

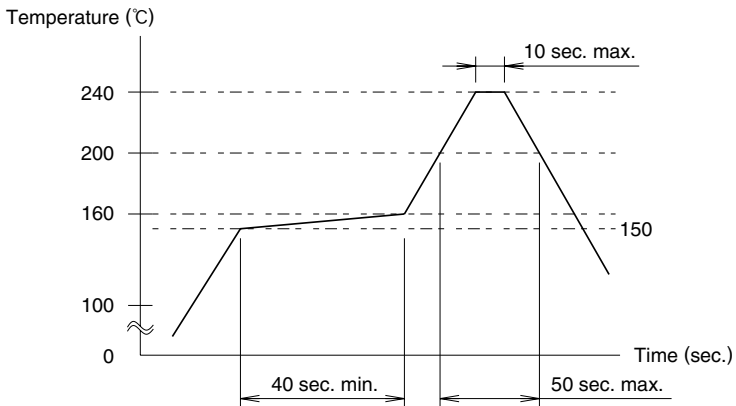

● Typical Solder Paste

①	Maximum temperature	: 240°C
②	Peak temperature	: 200°C to 235°C
③	Peak temperature time	: 10 sec. max.
④	200°C min.	: 50 sec. max.
⑤	150°C to 160°C	: 40 sec. min.

Metal mask thickness: 0.12mm
 Reflow cycles: 2 cycles

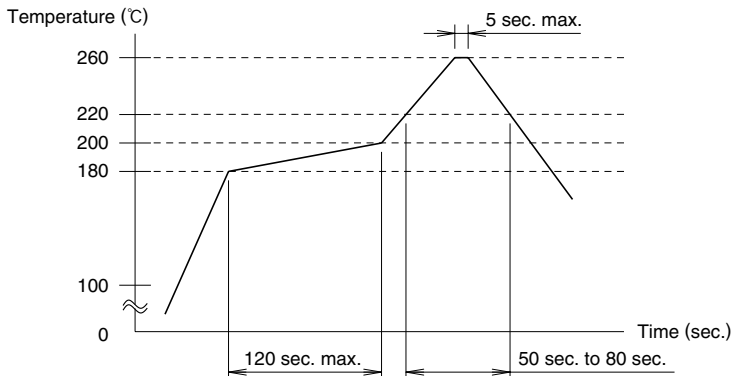

● Typical Lead-free Solder Paste

①	Maximum temperature	: 260°C
②	Peak temperature	: 240°C to 255°C
③	Peak temperature time	: 5 sec. max.
④	220°C min.	: 50 sec. to 80 sec.
⑤	180°C to 200°C	: 120 sec. max.

Metal mask thickness: 0.12mm
 Reflow cycles: 2 cycles

■ SMA conversion adapter

Part Number	CL No.	RoHS
MS-162-HRMJ-1	358-0210-5	YES

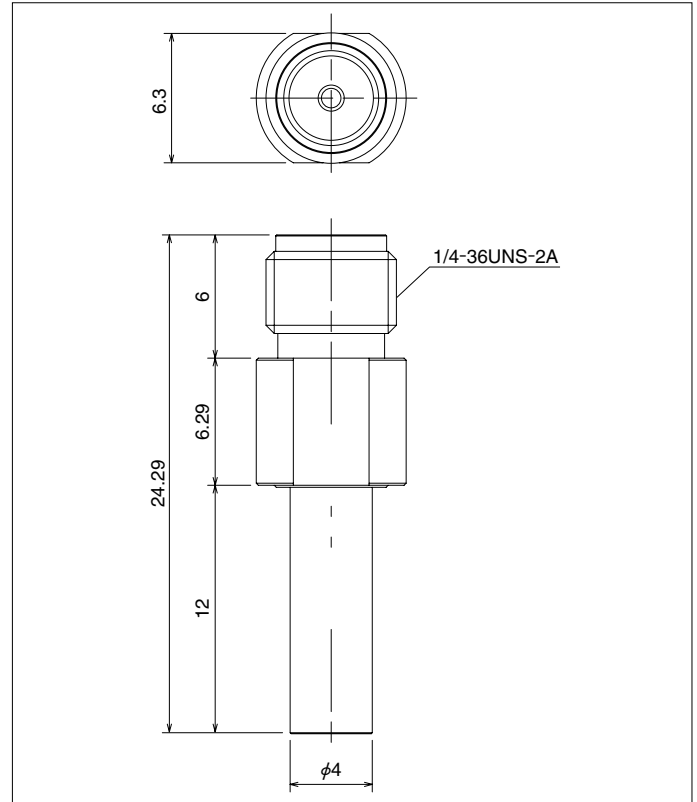

◆ Packaging Specifications

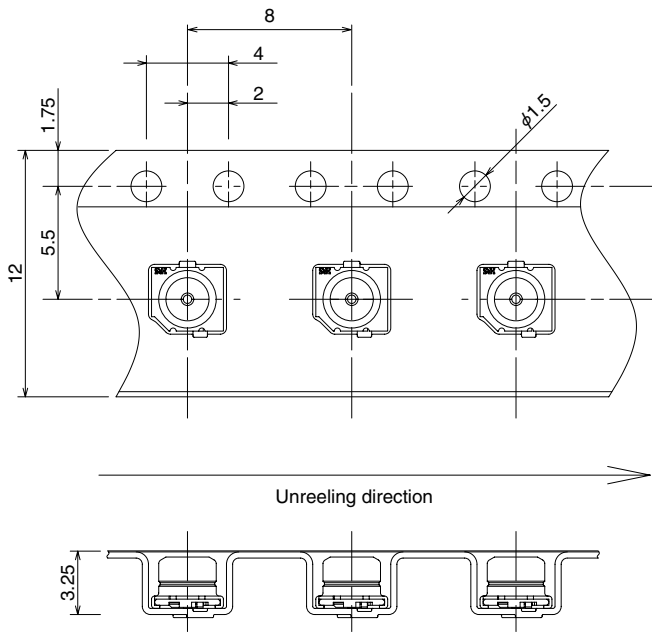

● Reel dimensions

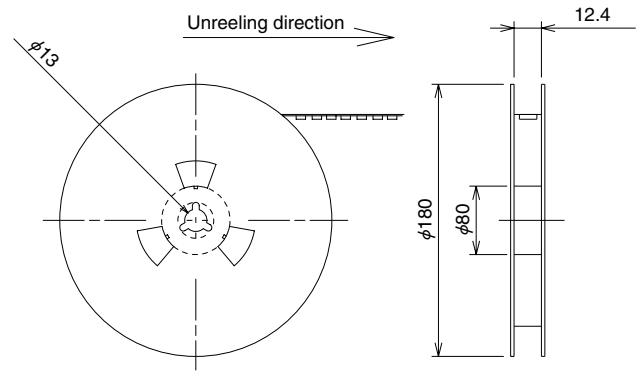

◆ Recommended Nozzle Dimensions

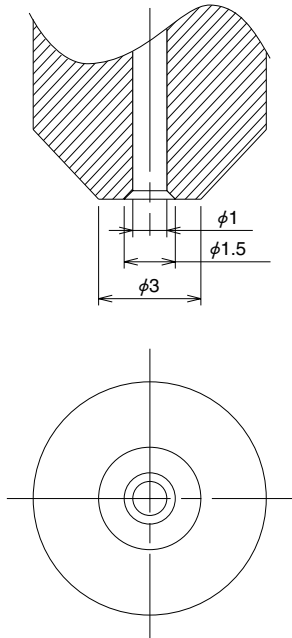

◆ Example of Application

Installed in portable devices

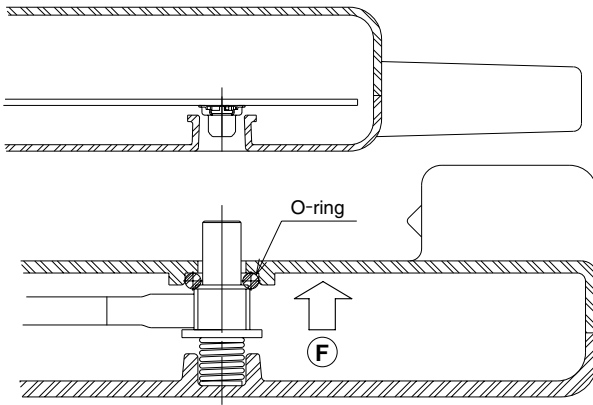

Note 1: When mounting the MS-162-C(LP)-1 make sure that the recommended self alignment distances and angle can be maintained.

Note 2: When fully mated the spring force (F) must be 10N to 15N.

Installed in test fixture

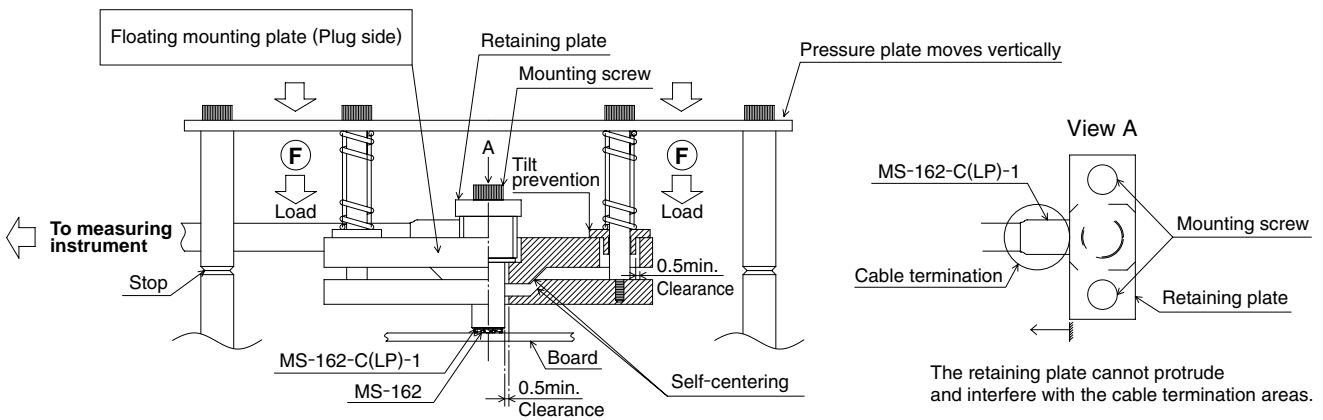

Note 1: When mounting the MS-162-C(LP)-1 make sure that the recommended self alignment distances and angle can be maintained.

Note 2: When fully mated the spring force (F) must be 10N to 15N.

Axial misalignment distance

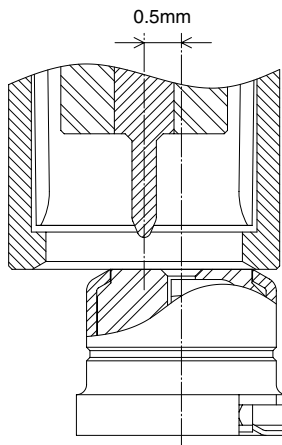

Allowable angular misalignment for mating

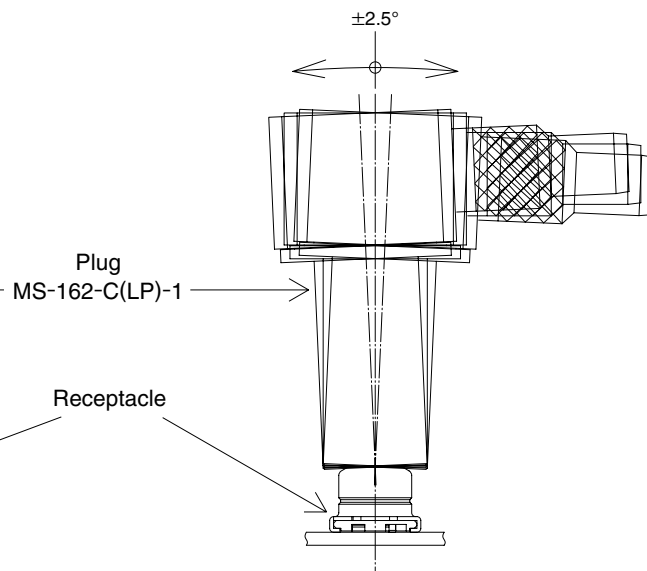

◆Precautions

1. Do not use the washing process.
2. Do not use hand soldering for mounting of MS-162.
3. When using a heat gun, hot plate, or similar methods, limit the temperature to 260°C applied for 10 seconds max.
4. Consult Hirose if your application, installation methods or end-user environment are different than the recommended.
5. Please refrain from using the product in environments specifically affected by dust, high humidity, gases, very high temperatures and very low temperatures.
6. When used as an RF interface of a portable terminal, consider using a rubber cap or other means of protection against intrusion of dust, dirt or other harmful elements.
7. When using, assure that the plug is fully inserted to the surface (P), as shown.

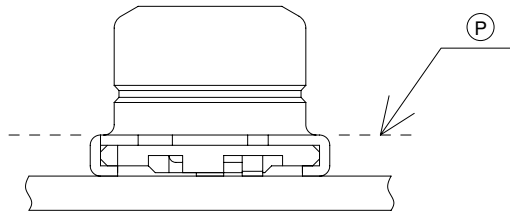

HIROSE ELECTRIC CO.,LTD.

5-23,OSAKI 5-CHOME,SHINAGAWA-KU,TOKYO 141-8587,JAPAN
PHONE: 81-3-3491-9741, FAX: 81-3-3493-2933
<http://www.hirose.com>
<http://www.hirose-connectors.com>
